

<b>Whirling Circles</b>	<b>14 <i>Stitchin'Pal</i> Designs</b>
<b>Catalog Code - SPS5</b>	
<p><b>Available Now!</b>  <i>Leaving the Bones Behind</i>, is a suspense novel set in the Northwest in the state of Montana, with threads leading the reader to Seattle, to Long Island, to Sparta, Tennessee, to the Alagnak River in Alaska, to Japan, and Singapore. A work of fiction, the subject matter is sure to strike a chord with many readers—especially baby boomers.</p> <p><b>Go to: <a href="http://www.garywatsonbooks.com">www.garywatsonbooks.com</a></b>  For more details on the story, the cause behind the book and how you can participate in developing the principle character for Gary's next novel</p>	 <p>It's sort of a Michael Crichton-esque take on a Nicholas Sparks story, <i>The Notebook</i>. This thought-provoking novel is about the ravages of Alzheimer's disease, the ethical dilemmas inherent in scientific advances, and the search for a dignified space in-between. Readers will be absorbed in Gary's story from the very first page, and should be prepared to experience a full range of emotions as they work their way toward the astonishing conclusion of <i>Leaving the Bones Behind</i>.</p> <p>Available now on <a href="http://Amazon.com">Amazon.com</a></p>
<b>Whirling Circles Block Designs</b>	<b>Whirling Circle E2E Designs</b>
 <p><i>Whirling Circles - Blk1-1084</i>  design by Gary Watson Copyright 2009</p>	
<b>Whirling Circles 1084</b>	<b>Whirling Circles 1054 Pattern on Fleece backing</b>
<b>Continuous Line Edge to Edge</b>	Deborah recently used 1054 on a baby quilt. It turned out to be really special - Using Creative Studio she achieved this outcome by Selecting the E2E Set up, and then staggered the rows using the "alternating rows" feature. Finally she used the vertical spacing tool and entered in a negative spacing to tighten the pattern enough to make the swirls almost come together. Try it! - It really make

the pattern pop.

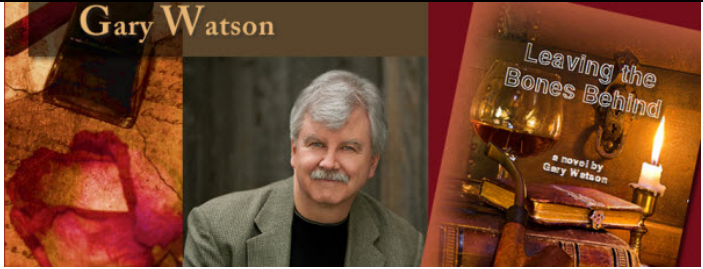
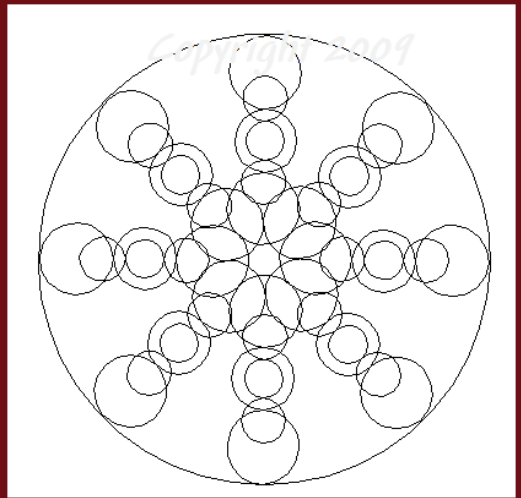
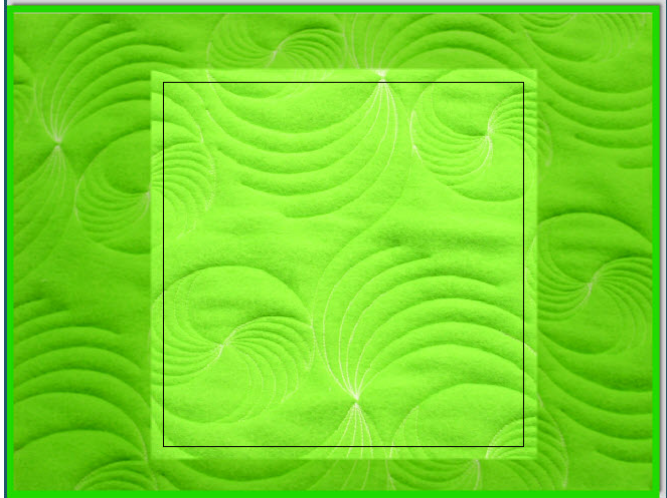
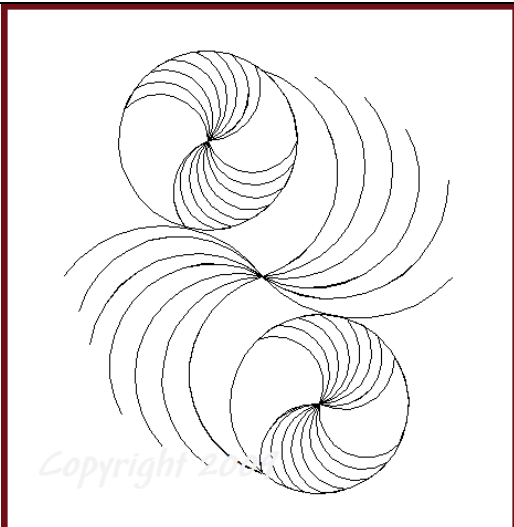

Copyright 2009

*Whirling Circles - E2E - 1054*

*design by Gary Watson Copyright 2009*

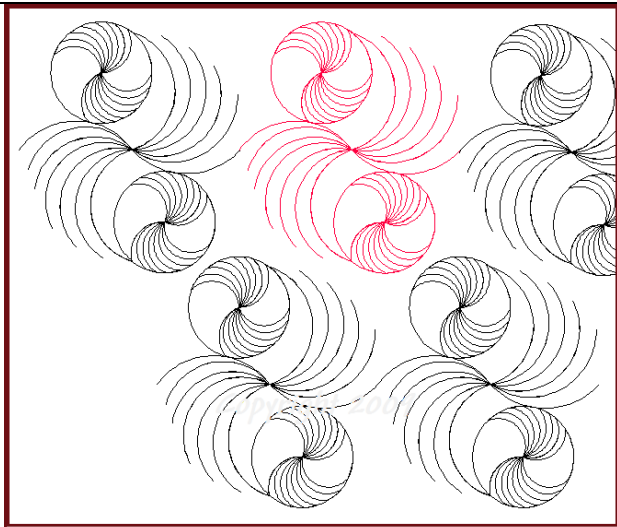

*Whirling Circles - E2E - Illustration - 1054i*

*design by Gary Watson Copyright 2009*

**Whirling Circles 1054**

**E2E Illustration - 1054i**

**Continuous Line Edge to Edge**

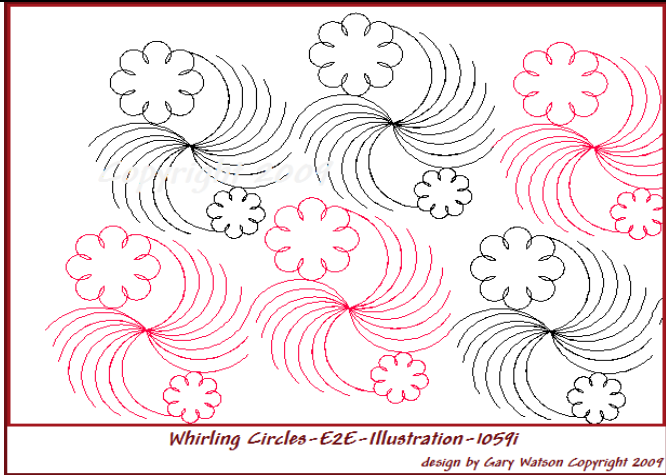
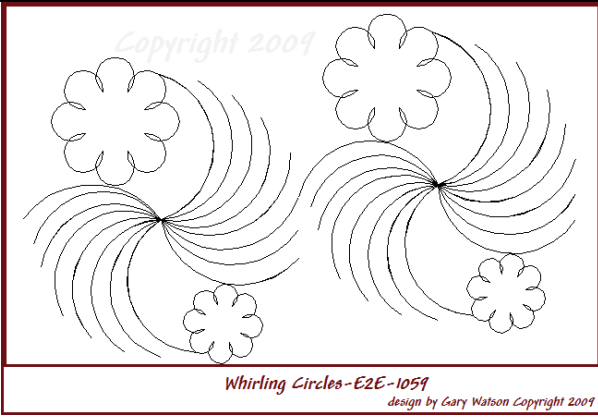

**Whirling Circles 1059**

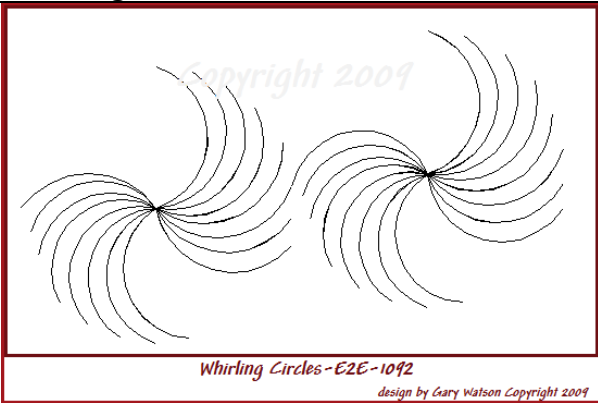

**E2E Illustration - 1059i**

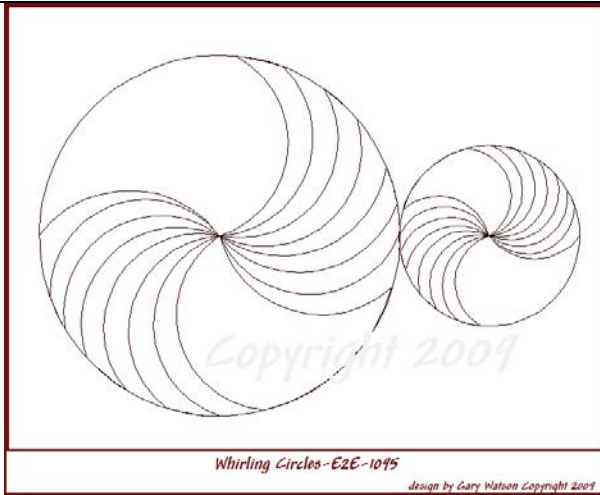

**Whirling Circles 1092**

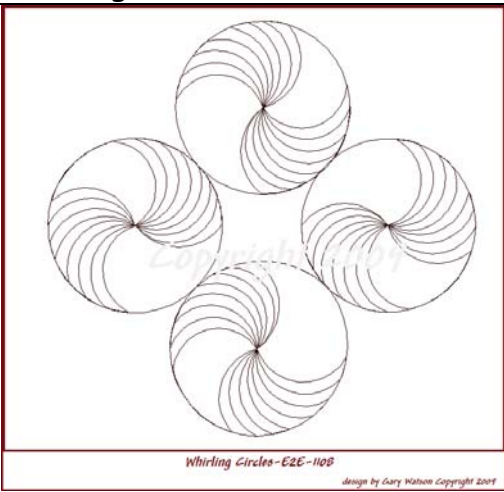

**Whirling Circles 1095**

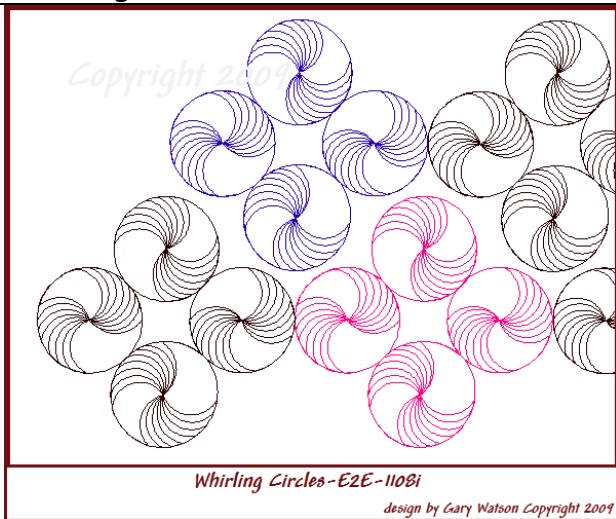

**Whirling Circles 1108**

**E2E Illustration - 1108i**

**Accessory Pals (Triangles, P2P, and Border Corner Pieces)**

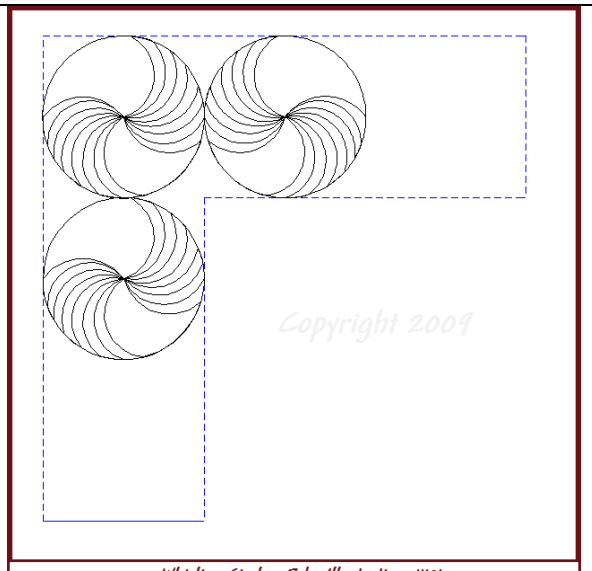
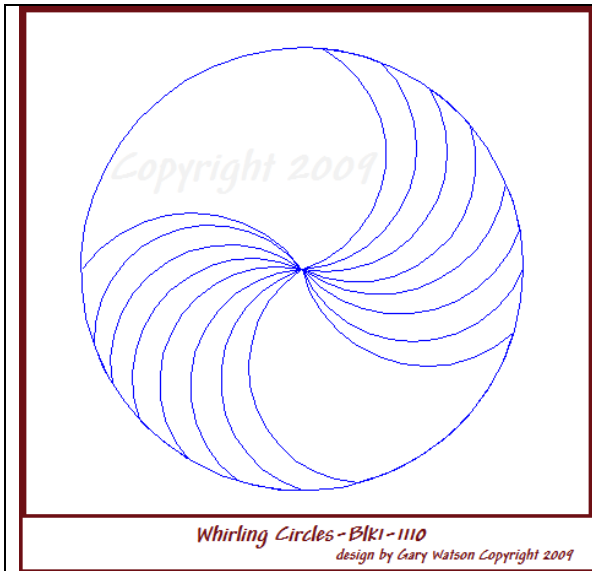

**Whirling Circles 1110**

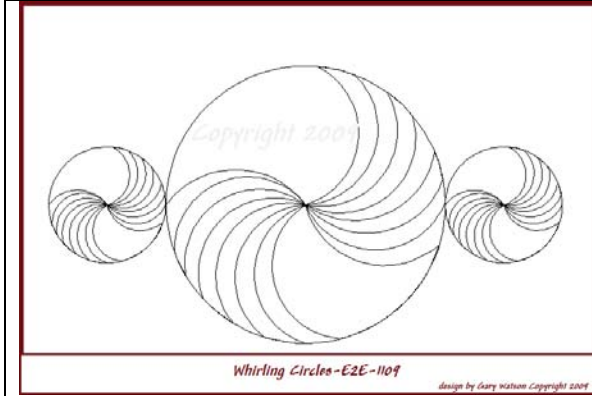

**Whirling Circles 1109**

**Accessory Pals (Triangles, P2P, Border Corners)**

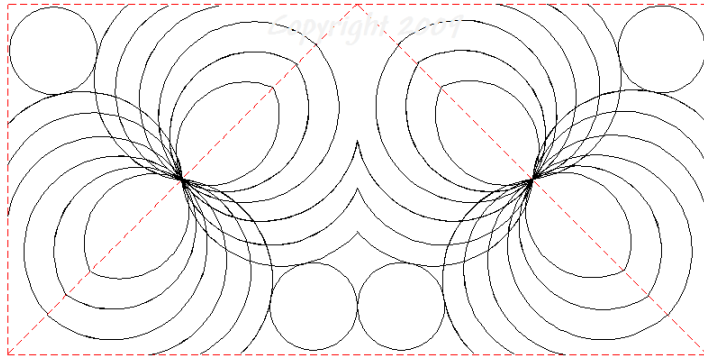

*WhirlingCircus-FGTRI-1062*

*design by Gary Watson Copyright 2009*

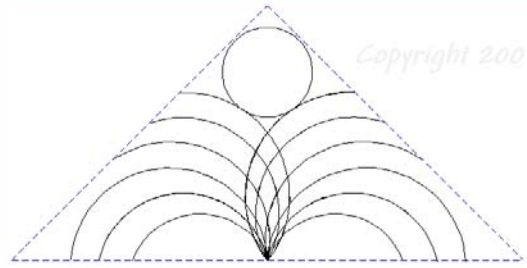

*Whirling Circles-TRI-1064*

*design by Gary Watson Copyright 2009*

**Whirling Circles 1062**

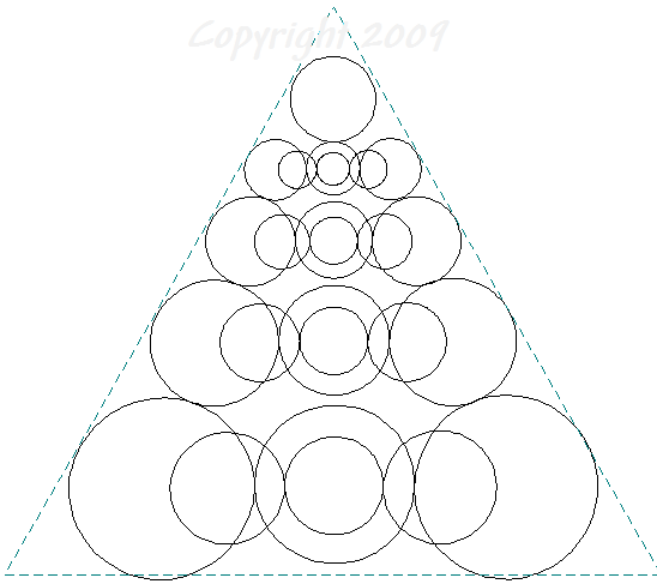

*Whirling Circles-Equal Sided TRI-1102*

*design by Gary Watson Copyright 2009*

**Whirling Circles 1064**

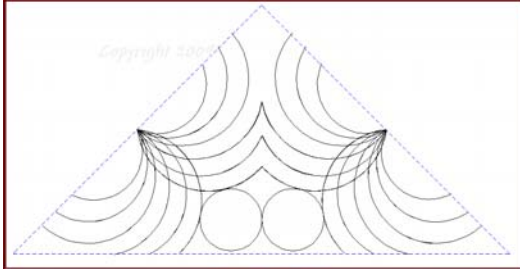

*Whirling Circles-TRI-1069*

*design by Gary Watson Copyright 2009*

**Whirling Circles 1102**

**Whirling Circles 1063**

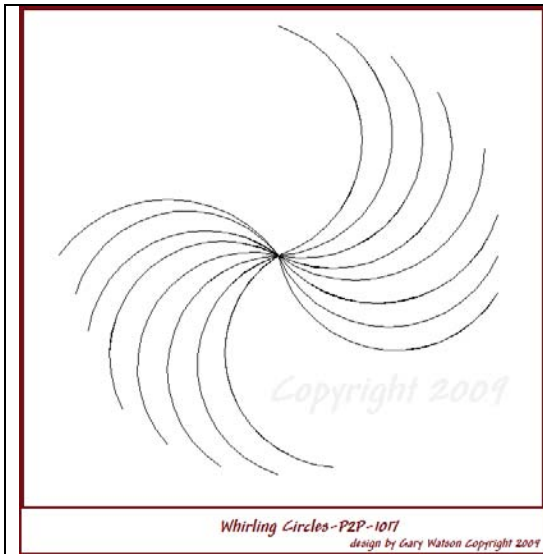

Whirling Circles 1017

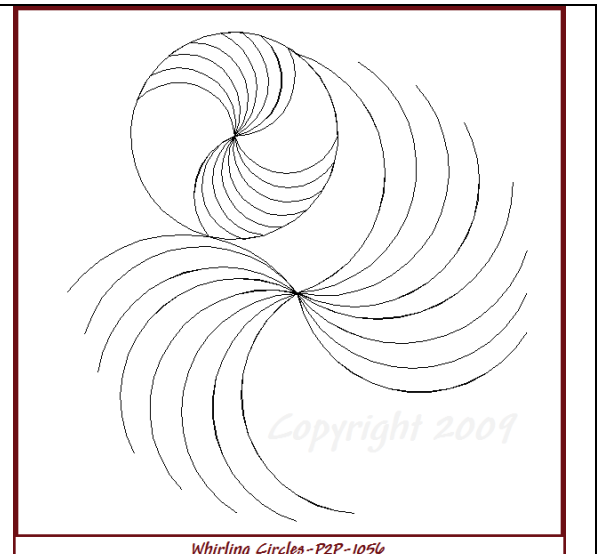

Whirling Circles 1056

## LICENSED TERMS OF USE

1. **Stitchin'Pals**—are patterns designed and copyrighted by Gary Watson of Quilts etcetera and NexTrac LLC. The official website is <http://www.quiltsxcetera.com> . Please address questions regarding copyright or witnessed violations of copyright to [gary@quiltsxcetera.com](mailto:gary@quiltsxcetera.com).
2. **LICENSEE** – The licensee of a Stitchin' Pal design by Gary Watson and/or Quilts Etcetera shall be a SINGLE INDIVIDUAL purchaser or their agent who is an actual person and not a corporate, business or organizational entity comprised of multiple users. Only the licensee is authorized to use the purchased patterns.
3. The copyright notice imbedded in each copyrighted design may not legally be removed from the pattern regardless of whether or not patterns are otherwise modified.
4. Patterns may be modified by the LICENSEE when quilting but only for that purpose.

**Notice:** Patterns may not be duplicated with or without modifications and used for any other purposes than explicitly stated under licensed terms of use.

## LICENSED TERMS OF USE

5. **LICENSED TERMS OF USE** – Patterns may be used to quilt any number of personal objects EXCLUSIVELY by the licensee or their agent. If used in quilts or quilted items for resale, a credit for the quilting design must be given to Gary Watson or Quilts etcetera on the documentation (not necessarily on the label) displayed by the quilted item.
6. LICENSEES are encouraged to use Stitchin' Pal patterns to quilt for others in a cottage industry style business which performs quilting services.
7. The LICENSEE can use the patterns to operate up to three—total—individual computerized long arm machine quilters regardless of manufacturer.
8. The LICENSEE may not put or use these patterns on a rental or leased machine that would allow anyone other than the licensee or their agent to access the patterns.
9. Royalty fee based licensing of all Stitchin' Pal designs by Gary Watson for the manufacture of related goods must be arranged with Quilts etcetera or it's parent NexTrac LLC.
10. All promotional displays of patterns, must reflect the copyright of the designer.
11. **TRANSFER OF LICENSE** – No transfer of license is possible unless the original licensee is deceased, or signs an affidavit confirming that they no longer have any equipment that would allow them to use the patterns in question, and that they have/will not be purchasing any equipment that will allow them to use the patterns in the foreseeable future.